

INSTALLATION AND MAINTENANCE INSTRUCTIONS

**VDRS Vane-type Waterflow Detector with Retard
(Saddle type)**

No.9 Tongbao Road,SanduoTown,Gaoyou,Jiangsu China.

Tel:+86-0514-84845308

SPECIFICATIONS

Contact Rating:	10A @ 125/250VAC ~; 3A @ 24VDC ---
Flow Rate:	15 to 37.8L/min (4 to 10 gpm)
Static Pressure Rating:	31bar (450 psi)
Dimensions, Installed:	See Table1
Operating Temperature Range:	32 to 155°F (0°C to 68°C)
Compatible Pipe:	Steel pipe, schedule 10 through 40 (See chart below)
Shipping Weight:	1.5 to 3.5 Kg (according to size)



IMPORTANT Please Read Carefully and Save

This instruction manual contains important information about the installation and operation of VDRS waterflow detector. Please read all the instructions carefully before beginning. Purchaser must leave this manual or a copy of it with the end user.



Installation must be performed by qualified personnel and in accordance with all nation and local codes and ordinances. When installing, removing, wiring and maintaining the detector, be sure to disconnect the power source. Failure to do so may result in electric shock or burnout.

Hazard of Electric Shock: Do not touch the live parts of the terminals while power is on. Otherwise it may cause electric shock.

Risk of explosion: Do not use the VDRS detector in a hazardous environment such as flammable gas or explosive gas. Otherwise serious injury or death could result.



The VDRS waterflow detector shall be used in wet pipe fire sprinkler systems only. It shall not be used as sole initiating device in both deluge and preaction systems. Any misuse in either deluge system or preaction systems may result in an unintended discharge caused by a surge, trapped air or a short retard time.

Do not use the detector on copper pipe. The clamping forces of the mounting bolts may make the copper pipe deformation and prevent the detector from proper function.

Do not install steel or iron pipe sections in copper piping for mounting a waterflow detector. Incompatibility between the dissimilar metals will cause bi-metallic corrosion.

Be sure the direction of flow arrow and directional cover point in the correct direction or else water flow will go unreported. See **FIGURE 3** and **FIGURE 6**.

OPERATION PRINCIPLES

The waterflow detectors mount to water-filled pipes in fire sprinkler systems. When water flow rate in the pipe is 10 gallons per minute or more, the flow force will deflect the vane of the detector, which produces a switched output, usually after a specified delay. The switch will not actuate if the flow rate is less than 4 gallons per minute.

With a pneumatically controlled mechanical delay mechanism equipped in the detector, the output may retard for a specified period that preset according to

the requirements. Delays do NOT accumulate, they would reset if the flow of water stops or drops below minimum triggering flow rate.

Model	Nominal Pipe Size mm (in)	Pipe Schedule	Rated Working Pressure bar (psi)
VDRS50	50 (2)	10 thru 40	31 (450)
VDRS65	65 (2½)	10 thru 40	31 (450)
VDRS80	80 (3)	10 thru 40	31 (450)
VDRS100	100 (4)	10 thru 40	31 (450)
VDRS125	125 (5)	10 thru 40	31 (450)
VDRS150	150 (6)	10 thru 40	31 (450)
VDRS200	200 (8)	10 thru 40	15.5 (225)

INSTALLATION GUIDELINES

Before installing any waterflow alarm device, be thoroughly familiar with:

NFPA 72: National Fire Alarm Code

NFPA 13: Installation of Sprinkler Systems

NFPA 25: Inspection, Testing and Maintenance of Sprinkler Systems Other applicable NFPA standards, local codes, and the requirements of the authority having jurisdiction

NOTE: Installation methods other than those listed in this installation manual may prevent the detector from reporting the flow of water in the event the associated fire sprinkler system is activated by a fire. Iron Man is not responsible for devices that have been improperly installed, tested, or maintained.

1. Mount the detector where there is adequate clearance for installation and removal and a clear view of it for inspections. See **FIGURE 1** for mounting dimensions.
2. Locate the detector 6 to 7 feet above the floor to protect from accidental damage.
3. On horizontal pipe, position the detector on the top or side of the pipe. Do not mount it upside down because condensation may collect in the housing and impair the operation of the detector. For vertical flow applications, mount the detector on pipe through which water flows upward. Otherwise, the unit may not operate properly.
4. Mount the detector at least 6 inches from a fitting that changes the direction of water flow or pipe diameter and no less than 24 inches from a valve or drain.
5. Be sure the direction of flow arrows on the saddle matches the direction of flow in the pipe.

MOUNTING INSTRUCTIONS

1. Drain the pipe.

2. Cut a hole of a proper diameter in the pipe at the arranged location, as shown in **FIGURE 2**. Before drilling, use a punch to mark the drill site

IM-IMI-001

1

Ver1.0

to prevent the bit from slipping. Center the hole on the pipe, and be sure the hole is perpendicular to the center of the pipe. If the hole is off center, the vane will bind against the inside wall of the pipe. When drilling the hole with a hole-saw, make certain that the chip of the cut does not remain in the pipe. See **Table 2** for the hole size.



When drilling the hole with a hole saw, make certain that the center of the cut does not remain in the pipe.

3. Remove burrs and sharp edges from the hole. Clean and remove all scale and foreign matter from the inside of the pipe for a distance equal to the pipe diameter on either side of the hole to ensure free movement of the vane. Clean the outside of the pipe to remove dirt, metal chips, and cutting lubricant.
4. Seat the gasket against the saddle and mount the detector directly to the pipe. Carefully roll the vane opposite the direction of flow and insert it through the hole (see **FIGURE 3**). Seat the saddle firmly against the pipe so that the locating boss goes into the hole.
5. Install the U-bolt, tightening the nuts alternately to ensure a uniform seal (see **Table 2** for torque values).
6. Remove the cover with the tamper proof wrench provided. Move the actuator lever back and forth to check for binding. If the vane binds, remove the detector and correct the cause before proceeding.



Be sure the direction-of-flow arrow of the saddle point in the correct direction or else the waterflow detector would be invalid. See **FIGURE 3** and **FIGURE 6**.

FIGURE 1. MOUNTING DIMENSIONS:

88mm(3.5")

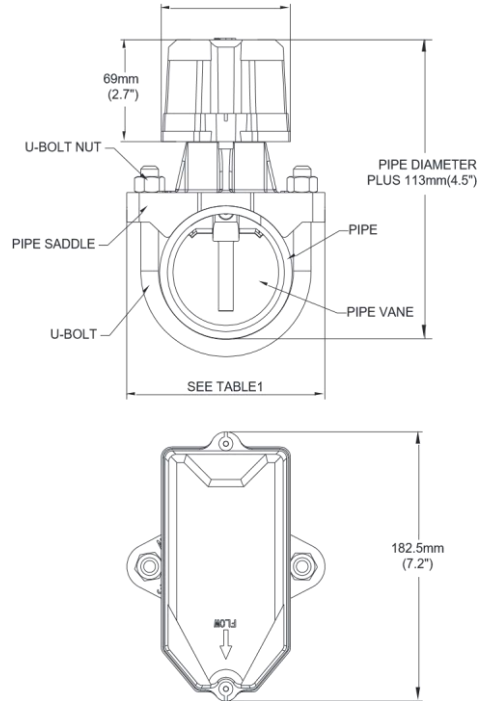
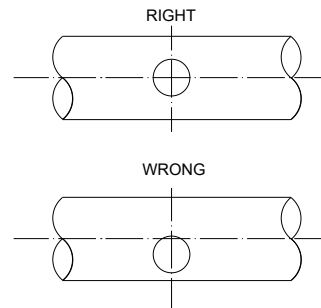

TABLE 1:

DN	Dimension mm (in)	DN	Dimension mm (in)
50	116 (4.6)	125	195 (7.7)
65	116 (4.6)	150	225 (8.8)
80	135 (5.3)	200	270 (10.6)
100	170 (6.7)		

FIGURE 2. MOUNTING HOLE LOCATION:



REMOVE BURRS FROM EDGE OF HOLE. CLEAN OUT SCALE AND FOREIGN MATTER FROM INSIDE WALL OF PIPE.

TABLE 2:

DN	Hole size mm (in)	Torque (N·M)

50, 65	31.8mm+1.6mm (1 ¹ / ₄ in+ ¹ / ₁₆ in)	41-47
80, 100, 125, 150, 200	50.8mm+1.6mm (2 in+ ¹ / ₁₆ in)	62-68

PRE-OPERATION TESTING

1. Fill the fire sprinkler system and check for leaks around the waterflow detector. If it leaks, first check for the proper torque on the U-bolt nuts. If the leak persists, drain the system and remove the detector (refer to Maintenance). Check for dirt or foreign objects under the gasket, and make sure that the pipe surface is not dented. Reinstall the detector and check again for leaks. Do not proceed until all leaks have been stopped.
2. Connect an ohmmeter or continuity tester across the COM and B-NO switch terminals. The ohmmeter should indicate an open circuit.
3. Deflect the vane and hold it until the pneumatic delay shaft releases the switch buttons. The ohmmeter or continuity tester should show a short circuit after the delay has elapsed. If there is no delay, check the setting of the delay adjustment dial.

FIELD WIRING

1. The detectors have two SPDT switches. Switch contacts COM and B-NO are closed when water is flowing and open when it is not. Connect the switches, as shown in **FIGURE 7**, depending on the application.
2. When connected to a listed fire sprinkler/fire alarm control panel, the initiating circuit must be unable to be silenced.
3. A ground screw is provided with all waterflow detectors. When grounding is required, clamp wire with screw in hole located between conduit entrance holes. See **FIGURE 4**.
4. If a second conduit entry is required, remove the knockout plug using a flat blade screwdriver as shown on **FIGURE 4**. Strike sharply with a hammer to pierce the wall of the knockout plug. Move to an adjacent wall section and repeat until the plug falls out. Make sure that the waterflow detector is supported adequately during this operation to avoid injury.
5. Use proper waterproof conduit fittings where required.

FIGURE 3. ASSEMBLY DIAGRAM:

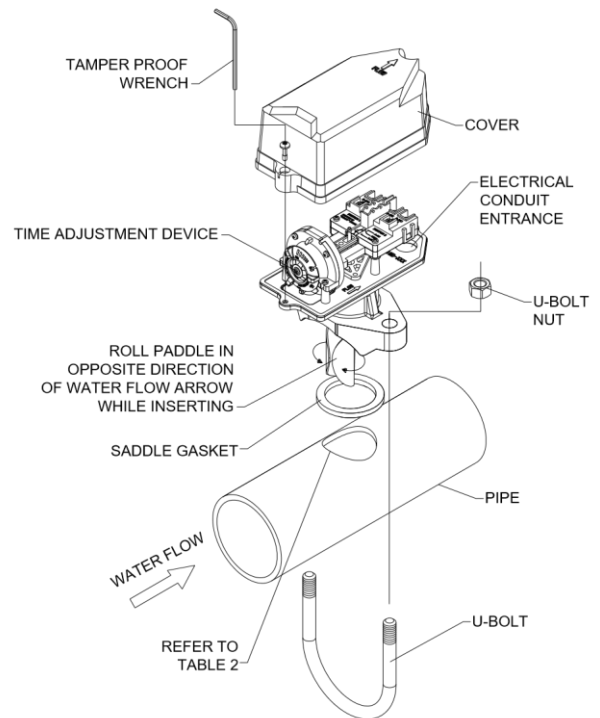

High Voltage Hazard. Do not handle live AC wiring or work on a device to which AC power is applied. Doing so may result in injury or death.

MECHANICAL DELAY ADJUSTMENT

The pneumatic delay is preset at the factory to 20 seconds. To adjust the setting, turn the adjustment dial clockwise to increase the delay, counterclockwise to decrease it. The delay is adjustable from 0 to 90 seconds max. See **FIGURE 5**. As a point of reference when setting time delay in dark environments, the **Bulge** on the dial plate indicates an approximate 20 second time delay and the **Notch** indicates an approximate 40 second time delay.

NOTE: Set the delay to the minimum required to prevent false alarms from flow surges. Periodically test time delay as required by Authority Having Jurisdiction or code authority.

OPERATIONAL TESTING

Always notify a central station monitoring waterflow alarm before repairing, maintaining, or testing waterflow alarm devices.

1. Replace the cover and tighten the tamper proof screws with the tamper proof wrench. Store the wrench in a secure place.
2. Open the test valve and time how long it takes for the detector to indicate a flow condition. The detector should remain activated until the test valve is closed. Air pockets in the sprinkler system may increase the

001 3 apparent delay.

MAINTENANCE

To prevent accidental water damage, control valves should be shut tight and drain the system completely before waterflow detectors are removed or replaced.

Inspect the detectors in accordance with applicable NFPA codes and standards for leaks and replace if a leakage occurs.

Test the detectors at least quarterly, as described under Operational Testing, to ensure proper operation.

Under normal conditions, VDRS waterflow detectors should provide years of trouble-free service. However, if the delay mechanism becomes faulty, a replacement kit is available. To replace the delay mechanism, request Part No. IMWIDY. Complete instructions are enclosed with replacement parts. The mechanism can be easily replaced without removing the detector from the pipe or draining the pipe. Do not repair or replace any other waterflow detector components. If any other part of the detector does not perform properly, replace the entire detector. Installation methods other than those listed in this installation manual may prevent the device from reporting the flow of water in the event the associated sprinkler system is activated by a fire, Iron Man is not responsible for devices that have been improperly installed, tested, or maintained.

To remove a detector:

1. Drain the pipe.
2. Turn off electrical power to the detector and disconnect the wiring.
3. Loosen the nuts and remove the U-bolts.
4. Gently lift the saddle far enough to get your fingers under it. Then, roll the vane so it will fit through the hole while continuing to lift the waterflow detector saddle.
5. Lift the detector clear of the pipe.

FIGURE 5. DELAY ADJUSTMENT DIAL:

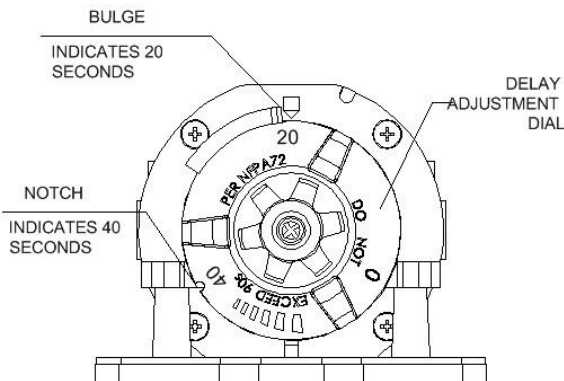

NOTE: RETARD TIME MAY EXCEED 90 SECONDS. ADJUST AND VERIFY THAT TIME DOES NOT EXCEED 90 SECONDS. NUMBER ON DIAL IS APPROXIMATE TIME DELAY IN SECONDS WITH AN ACCURACY OF +/-50%.



If a vane breaks in a pipe, find and remove it. If it is not removed, the vane may restrict the flow of water to all or part of the fire sprinkler system.

FIGURE 4. KNOCKOUT PLUG REMOVAL:

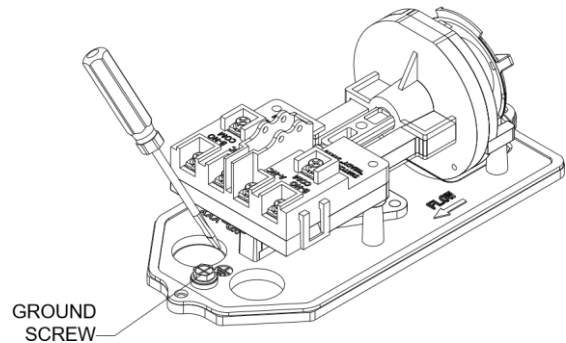

TO REMOVE KNOCKOUT: PLACE SCREWDRIVE AT INSIDE EDGE OF KNOCKOUT, NOT IN THE CENTER.

FIGURE 6. DIRECTIONAL COVER:

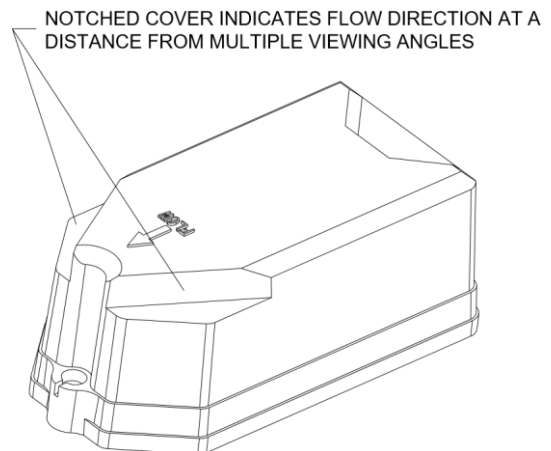
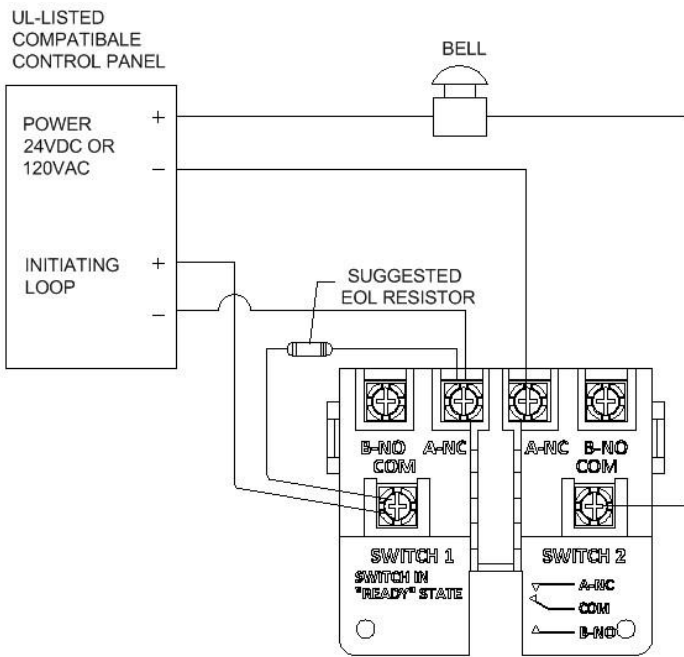

FIGURE 7. VDRS WIRINGS:



NOTE: COMMON AND B-NO CONNECTIONS WILL OPEN WHEN VANE IS DEFLECTED, I.E., WHEN WATER IS FLOWING. DUAL SWITCHED PERMIT APPLICATIONS TO BE COMBINED ON A SINGLE DETECTOR.

CONTACT RATINGS	
250VAC	10 AMPS
24VDC	3 AMPS

SCHEMATIC OF INDIVIDUAL SWITCH IN "VANE DEFLECTED" CONDITION

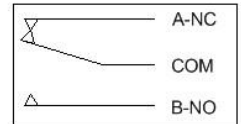

BREAK WIRE AS SHOWN FOR SUPERVISION OF CONNECTION. DO NOT ALLOW STRIPPED WIRE LEADS TO EXTEND BEYOND SWITCH HOUSING. DO NOT LOOP WIRES AROUND THE TERMINAL AND SERVE AS TWO SEPERATE CONNECTION.

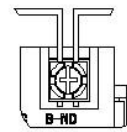

THE LIMITATIONS OF WATERFLOW ALARM DEVICES

- Waterflow detectors may not work or operate properly if sprinkler years. Hard water, however, may substantially reduce waterflow piping being monitored is plugged with pipe scale, mud, stones or detector service life. other foreign material. Sprinkler systems should be checked regularly 4. Waterflow detectors are not a substitute for insurance. Building for such blocking material, following the instructions in Chapter 5 of owners should always insure property and lives bei ng protected by NFPA Standard 13A. sprinkler systems.
- Alarms generated by the activation of waterflow detectors may not be 5. If valves controlling the water supply to a sprinkler system are received by a central station if telephone or other communication closed, vane-type waterflow detectors will not work. All valves lines to the detector are out of service, disabled, or open. controlling a sprinkler water supply should be sealed or locked in the
- Vane-type waterflow detectors have a normal service life of 10-15 normally open position. The normally open position should be monitored by a sprinkler supervisory switch.